

InteX[®]

starmix

Operation Manual:

操作手冊:頁

ANSG uClean 1420-1445 / ANSG uClean LD-1420-1445

ANSG uClean ADL-1420-1445 / ANSG uClean ARDL-1432-1455

Operating instructions

Bedienungsanleitung

Notice d'utilisation

Instrucciones para el manejo

Instruções de utilização

Istruzioni d'uso

Gebruiksaanwijzing

Betjeningsvejledning

Bruksanvisning

Driftsinstruks

Käyttöohje

Οδηγίες χειρισμού

Kullanım kılavuzu

Instrukcja obsługi

Kezelési utasítás

Návod k obsluze

Návod na obsluhu

Instrukțiuni de utilizare

Navodila za uporabo

Upute za rad

Uputstvo za upotrebu

Инструкция за експлоатация

Kasutusjuhised

Naudojimo instrukcijos

Lietošanas instrukcija

Руководство по эксплуатации

操作说明

WARNING! To reduce the risk of injury or tool damage, the user must read this instruction manual before operating the machine. Failure to read this manual may void warranty.

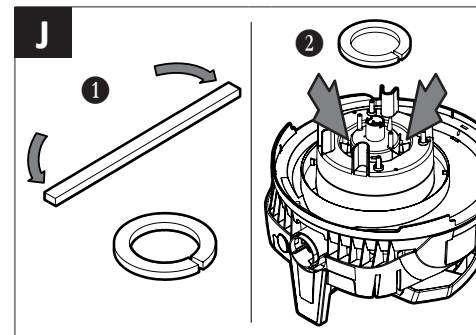
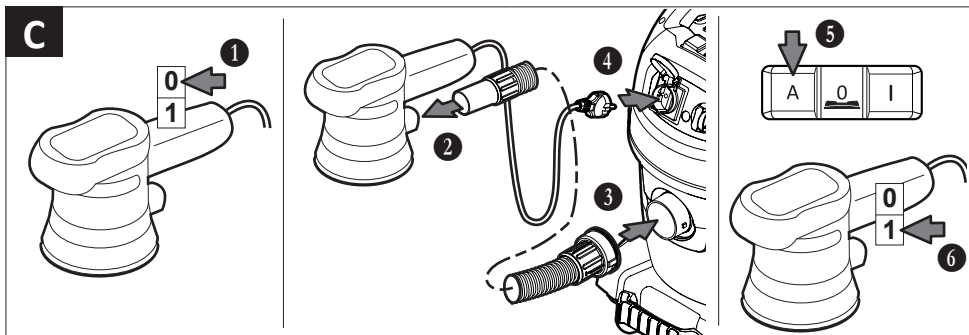
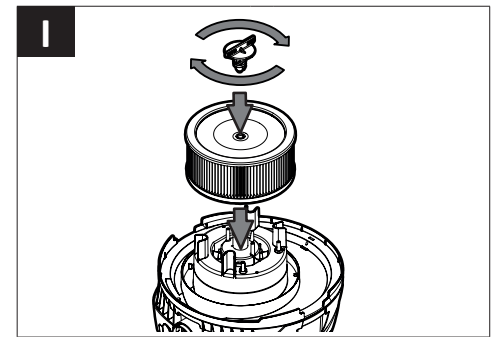
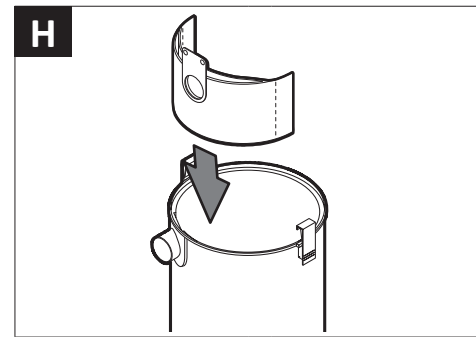
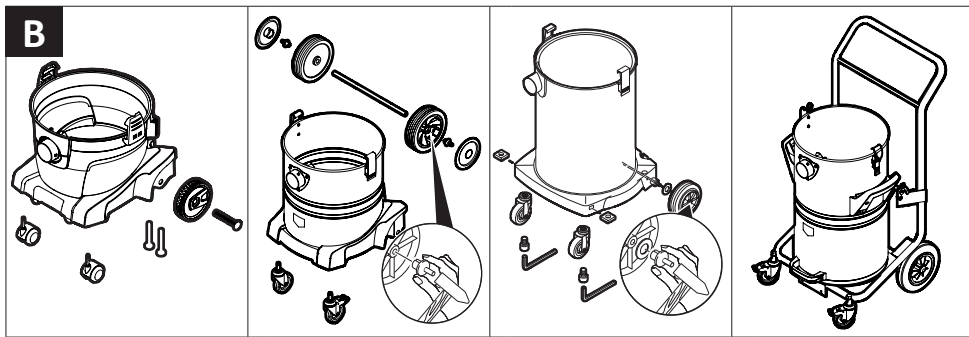
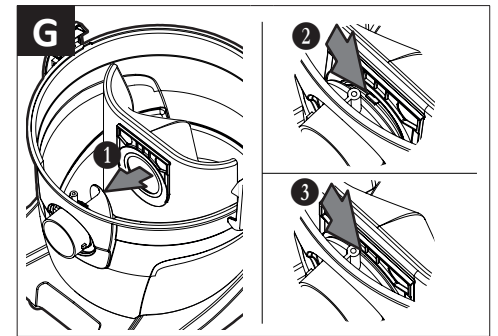
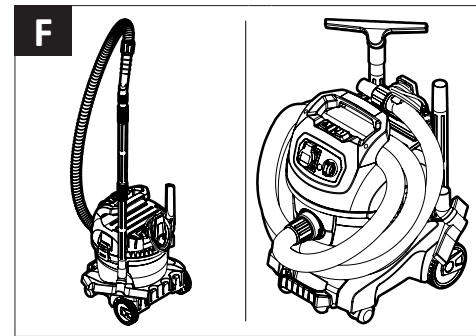
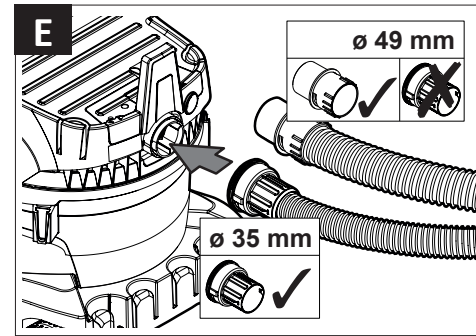
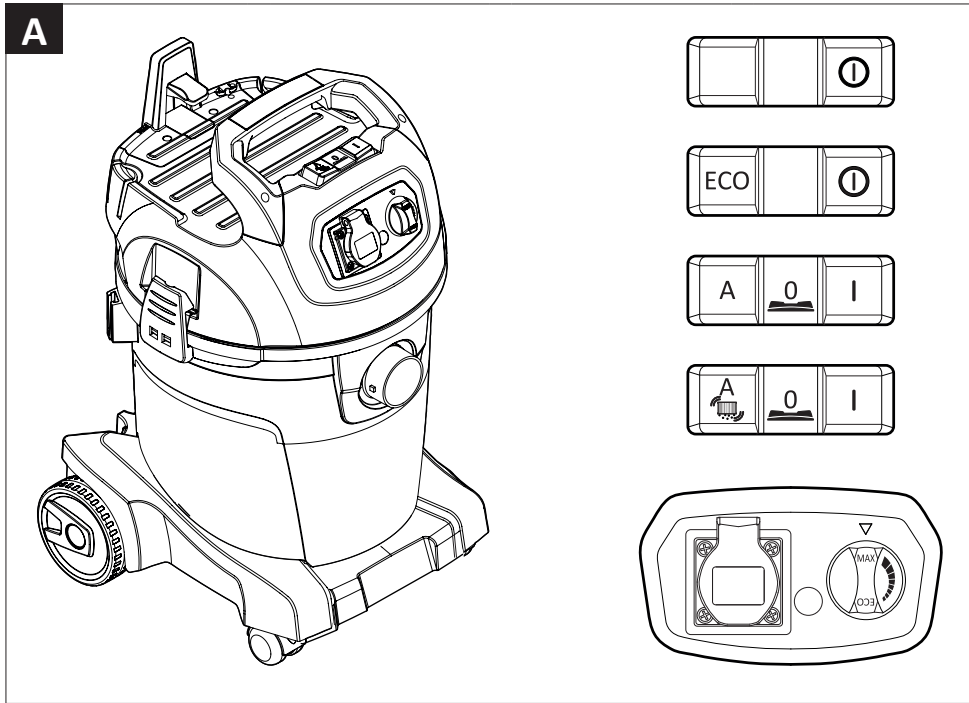







1 Important safety information

Carefully read the operating instructions all the way through before operating the equipment and retain them for future reference.

The pictures in these instructions refer to all available versions of the model and may be different from the actual scope of delivery.

Explanation of symbols and signs used

 This is the warning symbol. It warns against possible risk of injury. Follow all instructions which are marked with this sign to avoid injury or death. The warning symbol always appears in association with the signal words **DANGER**, **WARNING** and **CAUTION**.

Symbol	Signal word	Description
	DANGER	Identifies a hazard with a high degree of risk which will cause death or serious injury if not avoided.
	WARNING	Identifies a hazard with a medium degree of risk which could cause death or serious injury if not avoided.
	CAUTION	Identifies a hazard with a low degree of risk which could cause minor or moderate injury if not avoided.
	NOTICE	Identifies a hazard which could result in material damage if not avoided.
		Identifies a requirement which needs to be met before an action is taken.
1./2./3.		Identifies steps to be taken one after the other by the user.
		Identifies the results of an action.

Qualification of the operating personnel

The vacuum cleaner must only be used by persons, who have been instructed in its correct usage and explicitly commissioned with the task of operating it.

The dust extractor is not intended for use by persons (including children) with reduced physical, sensory or mental capabilities, or lack of experience and knowledge. Children should be supervised to ensure that they do not play with the dust extractor.

Intended use

The vacuum cleaner is suitable for vacuuming up dust and liquids.

Do not use the vacuum cleaner to vacuum up the following:

- Potentially explosive dusts
- Flammable or potentially explosive liquids or absorbent material soaked with these liquids
- Objects which are more than 60 °C hot

Do not run the vacuum cleaner in a potentially explosive environment.

Vacuum cleaners for dust class L are suitable for vacuuming/sucking up dry, non flammable dusts that are hazardous to health with workplace exposure limits >1mg/m³.



Vacuum cleaners which are not identified as being suitable for dust class L are only suitable for vacuuming/sucking up non-hazardous to health dusts.

Only operate the vacuum cleaner under supervision. Do not climb onto or sit on the vacuum cleaner.

The manufacturer does not accept liability for damages caused by misappropriation, inappropriate usage or incorrect repairs.

Avoid danger from electric shocks

The voltage on the rating plate must match the mains voltage. Only connect the vacuum cleaner to a sufficiently protected electric socket.

Do not pull the mains connection cable over sharp edges, do not bend it or clamp it. Only replace a damaged mains connection cable with one meeting the specifications in the Technical Data chapter.

Do not use the vacuum cleaner including accessories in the following cases:

- Mains connection cable or extension cable is defective or showing cracks.
- There is visible damage to the vacuum cleaner, e.g. cracks in the housing.
- If you suspect an invisible defect, e.g. after a fall.

In the following cases, switch the vacuum cleaner off and unplug it from the mains:

- If any foam or liquid is discharged
- In the event of a longer work interruption and after every use
- Before carrying out any maintenance or retooling

When unplugging, only pull on the mains plug and not on the mains connection cable. Never touch the mains plug with wet hands.

Do not open the vacuum cleaner outdoors in the rain or during a thunderstorm. Always keep the inside of the lid dry.

Only use the brushes supplied with the vacuum cleaner or those specified in the operating instructions. Using other brushes can compromise safety. Never allow electrical brushes to come into contact with the mains connection cable.

Avoid any danger during operation

Only for vacuum cleaners in dust class L: Make sure that the air exchange rate is high enough if the exhaust air is being fed back into the room (pay attention to applicable national regulations).

Inform operating personnel about the following points before work starts:

- Handling the vacuum cleaner
- Dangers originating from the material to be sucked up
- Safe disposal of the material sucked up

Do not use the blowing function in closed rooms. Only work with a clean suction hose. Do not stir up any dusts which are hazardous to health. Do not inhale dusts.

When being used in food processing businesses: Immediately clean the vacuum cleaner after use and disinfect it to avoid microbial contamination.

Avoid any danger during maintenance and repair

Only have repairs carried out by experts. Only use original accessories and spare parts.

2 Before the first start-up

Assembly

See Fig. B.

1. When unpacking, make sure everything is complete.
2. Immediately report any transport damage to the retailer.

3 Operation

Before every use, please note

Make sure that the following conditions are met:

- △ Vacuum cleaner, mains connection cable and suction hose are not damaged.
- △ All filters have been inserted and are not damaged.

Operating modes

Operating mode (depending on equipment)	Description	Switch position
Off	Wall socket under voltage	0
On	Wall socket under voltage, manual operation	I
Minimum suction power	Vacuum cleaner operates at low power	ECO
Maximum suction power	Vacuum cleaner operates at maximum power	MAX
Standby mode for automatic switch-on, infinitely adjustable speed control ECO-MAX	Vacuum cleaner is switched on and off by the electrical tool	A
Standby mode for automatic switch-on, infinitely adjustable speed control ECO-MAX, automatic filter cleaning	If the suction power drops, the filter is cleaned in breaks between work (= switched off electrical tool)	

Suck up dry materials

Tools required	Notes
Main filter (filter cartridge)	Vacuum cleaner, filter and accessories need to be dry. If frequently changing between wet and dry vacuuming, use a separate main filter.
Filter bag for dust-free disposal of fine-grained material to be sucked up	When vacuuming soot, cement, plaster, flour or similar dusts: Insert a filter bag in the dirt container so that the dust does not stick and or cake.
Accessories depending on the area of application	

1. Set required operating mode on the switch.
 - ↳ Vacuum cleaner is ready for vacuuming.
2. To adjust the suction power, select from the following options (depending on equipment):
 - Move switch to ECO position
 - Set speed on the switch

- Set auxiliary air slide on the handle tube

Suck up liquids

Volume of liquid	Tools required
Small volume of liquid	Main filter (filter cartridge) Water nozzle
Large volume of liquid	Main filter (foam) Water nozzle

1. Remove filter bag from the dirt container before sucking up liquids.
2. Slightly open auxiliary air slide on the handle.
3. Move switch to position I.

Before switching off the vacuum cleaner:

1. Remove suction nozzle from the liquid.
 - ↳ Residual water in the suction hose is sucked into the container and cannot leak out.

If the floating valve disrupts the suction process when the container is full:

1. Switch vacuum cleaner off.
2. Empty dirt container and filter cartridge.

Connect an electrical tool

See Fig. C.

Use socket on vacuum cleaners with automatic switch on/off (switch position A) to connect electrical tools. The vacuum cleaner is switched on and off by the electrical tool. In switch position 0, the socket can be used as an extension cable, e.g. for a light.

Connection value: Vacuum cleaner + electrical tool = max. 16 A (value depends on the country version, pay attention to technical data).



WARNING!

The socket on the vacuum cleaner is always live. Risk of injury due to electrical tool automatically starting up.

1. Before plugging in: Switch off electrical tool.

Blowing function

See Fig. E.

Only use the blowing function for cleaning, removing dust from and drying machines and appliances.

After work

See Fig. F.

1. Roll up mains connection cable and suction hose.
2. Store the accessories in the accessories holder.

Transport and storage

1. Before transport, close the locks on the upper part of the vacuum cleaner.
2. Pay attention to the weight of the vacuum cleaner, particularly if the dirt container is full.
3. Do not tilt the vacuum cleaner if there is liquid in the dirt container.
4. Store the vacuum cleaner dry and indoors, protected from frost.

4 Troubleshooting and repair

Fault	Cause	Remedy
Suction power drops	Lid not properly closed	Close lid
	Filter dirty	Clean
	Filter bag full	Change
	Container full	Empty
	Motor protection filter blocked	Clean
	Nozzle, tube or hose blocked	Clean
Vacuum cleaner does not start	Mains plug not in socket	Plug in
	No mains voltage	Check fuse
	Mains connection cable defective	Have it replaced
	Water sensor/floater has switched off	Empty container
	Switch in position A	Move switch to I
Vacuum cleaner does not start when the electrical tool is switched on	Electrical tool not plugged into socket on the vacuum cleaner	Plug mains plug into socket on the vacuum cleaner
	Switch not in position A	Move switch to A

Do not try anything else, contact customer services.

5 Maintenance

See Fig. G-H-I-J.

When maintaining and cleaning the vacuum cleaner, handle it in such a way that there is no danger for maintenance personnel and other people.

Only for vacuum cleaners in dust class L

For maintenance by the user, the vacuum cleaner must be

- dismantled,
- cleaned and
- maintained,

as far as possible without creating any danger to the maintenance personnel or other.

Suitable precautionary measures include

- Cleaning before dismantling,

- Provide local filtered positive ventilation where the vacuum cleaner is to be dismantled,
- Clean the maintenance area and
- suitable personal protection equipment.

Have a technical inspection carried out at least once a year by specialist personnel, e.g. checking for damage to the filter, air tightness of the vacuum cleaner and that the control equipment is working properly.

Contaminated items

When carrying out maintenance or repair work, all contaminated items which have not been adequately cleaned must be disposed of. Such items must be disposed of in impermeable bags in accordance with the applicable regulations concerning the disposal of such waste.

Emptying the container

Only permitted for dust with workplace exposure limits $>1\text{mg}/\text{m}^3$.

1. Switch the vacuum cleaner off, pull the mains plug out.
2. Open the latches.
3. Remove the cover and suction hose from the container.
4. Empty the container by pouring out.

Replacing filter cartridge

See Fig. I.

1. Switch the vacuum cleaner off, pull the mains plug out.
2. Open the latches.
3. Remove the cover from the container.
4. Loosen the locking screw.
5. Removing the filter cartridge.
6. Push new filter cartridge in a straight manner over the case, right up to the stop point.
7. Tighten the locking screw.

Dispose of filter cartridges, filter bags or disposal bags

Dispose of the filter cartridge, filter bag or disposal bag in accordance with national regulations.

Cleaning

Do not clean the vacuum cleaner with a high pressure cleaner. Only use a wet cloth and mild cleaning agents to clean it. Acids, acetone and solvents can etch parts of the vacuum cleaner.

Do not clean the filter cartridge with pressurised air.

6 Disposal



Old equipment contains valuable materials which are designed for re-processing. The vacuum cleaners must not be thrown away in the normal household waste, but should be disposed of at a suitable proper collection system, e. g. via your communal disposal location.

7 Genuine accessories

Description	Order No. ANSG uClean 14.. / LD 14.. / ADL 14..	Order No. ANSG uClean ARDL 14..
Filter cartridge FPP 3600	415109 (540986)	
Filter cartridge FPPR 3600		413464 (529776)

8 Technical Data

		ANSG uClean 14..	ANSG uClean LD 14..	ANSG uClean ADL / ARDL 14..
Voltage	V	220-240	220-240	220-240
Frequency	Hz	50/60	50/60	50/60
Power consumption (max.)	W	1400	1400	1400
Protection class		II □	II □	I ⊕
Air flow rate: at the fan	m³/h	248,4	248,4	248,4
Air flow rate: at the hose	m³/h	147	147	147
Negative pressure: at the fan	kPa	26	26	26
Negative pressure: at the hose	kPa	20	20	20
Filter surface area	cm²	2950	2950	2950 / 3400
Noise level	dB(A)	85	84	85
Power cord: type		H05VV-F 2x1,0	H05VV-F 2x1,0	H05VV-F 3G1,5
Power cord: length	m	8	12	8

	Tank volume l	Dimensions cm	Weight kg
ANSG 1420	20	41,7 x 39 x 55	8,9
ANSG 1432	32	41,7 x 39 x 64	9,3
ANSG 1445	45	48,3 x 48,3 x 79	12,4
ANSG LD-1422	22	46,1 x 43 x 57	10,3
ANSG LD-1420	20	42,5 x 39 x 55	9,2
ANSG LD-1432	32	42,5 x 39 x 64	9,5
ANSG LD-1435	35	46,1 x 43 x 70,3	11,0
ANSG LD-1445	45	48,3 x 48, x 79	12,8
ANSG ADL-1420	20	42,5 x 39 x 55	8,9
ANSG ADL-1432	32	42,5 x 39 x 64	9,3
ANSG ADL-1445	45	48,3 x 48,3 x 79	12,6
ANSG ARDL-1432	32	42,5 x 39 x 64	10,2
ANSG ARDL-1435	35	46,1 x 43 x 70,3	11,8
ANSG ARDL-1445	45	48,3 x 48,3 x 79	13,3

	Tank volume l	Dimensions cm	Weight kg
ANSG ARDL-1455 KFG	55	53 x 51 x 99	20,0



9 Declaration of conformity

Declaration of conformity

We hereby declare that the machine described below complies with the relevant basic safety and health requirements of the EC Directives, both in its basic design and construction as well as in the version put into circulation by us. This declaration shall cease to be valid if the machine is modified without our prior approval.

Product: Vacuum cleaner for wet and dry operation

Type: ANSG

The design of the appliance corresponds to the following pertinent regulations: EC Machinery Directive 2006/42/EU
EMC Directive 2004/108/EC

Applied harmonized standards: EN 60335-1:2012, EN 60335-2-69:2012, EN 62233:2008, EN 62233 BER.1:2008, EN 55014-1:2006+A12009+A2:2011, EN 61000-3-2:2006+A1:2009+A2:2009, EN 61000-3-3:2013, EN 55014-2:1997+A1:2001+A2:2008

Applied national standards and technical specifications: DIN EN 60335-1 (VDE 0700-1):2012-10, DIN EN 62233 (VDE 0700-366):2008-11, DIN EN 62233 Ber.1 (VDE 0700-366 Ber.1):2009-04, DIN EN 55014-1 (VDE 0875-14-1):2012-05, DIN EN 61000-3-2 (VDE 0838-2):2010-03, DIN EN 61000-3-3 (VDE 0838-3):2014-03, DIN EN 55014-2 (VDE 0875-14-2):2009-06

Authorized documentation representative: ELECTROSTAR GmbH, Stuttgarter Straße 36, 73262 Reichenbach/Fils, Germany

Carsten Gresser
Head of Quality Assurance

19.01.2015

Current Model: ANSG1432 Plastic - 32L

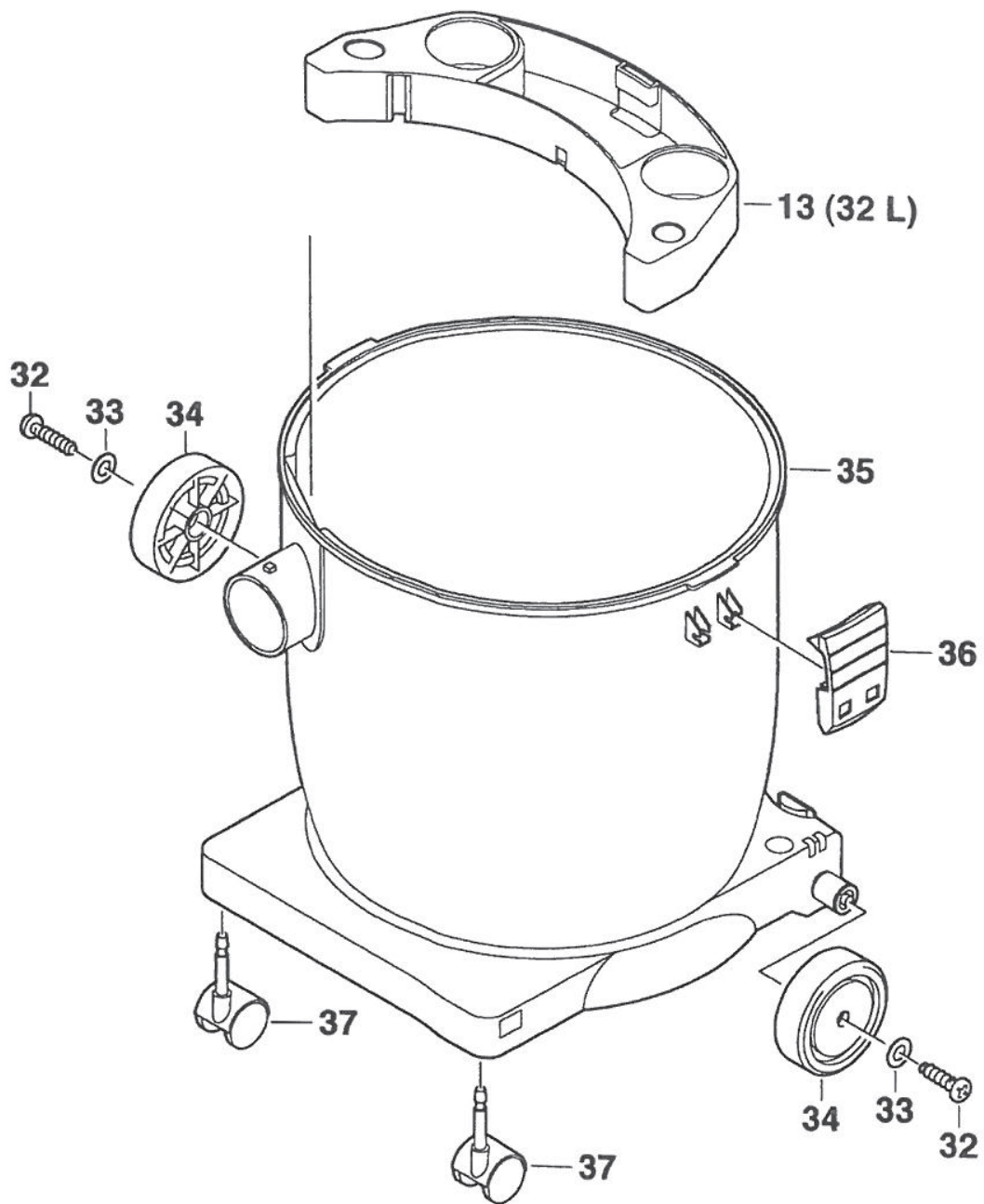

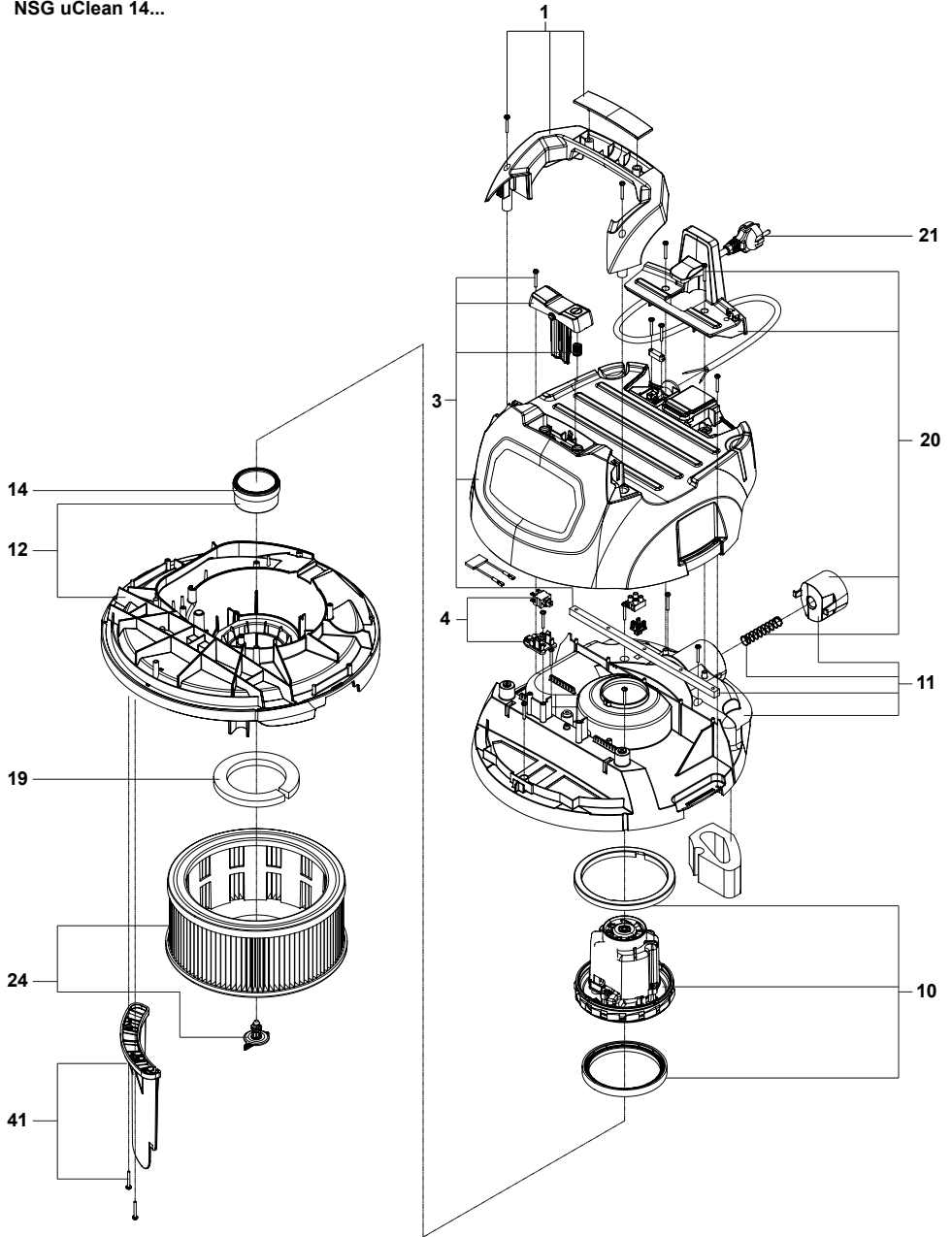

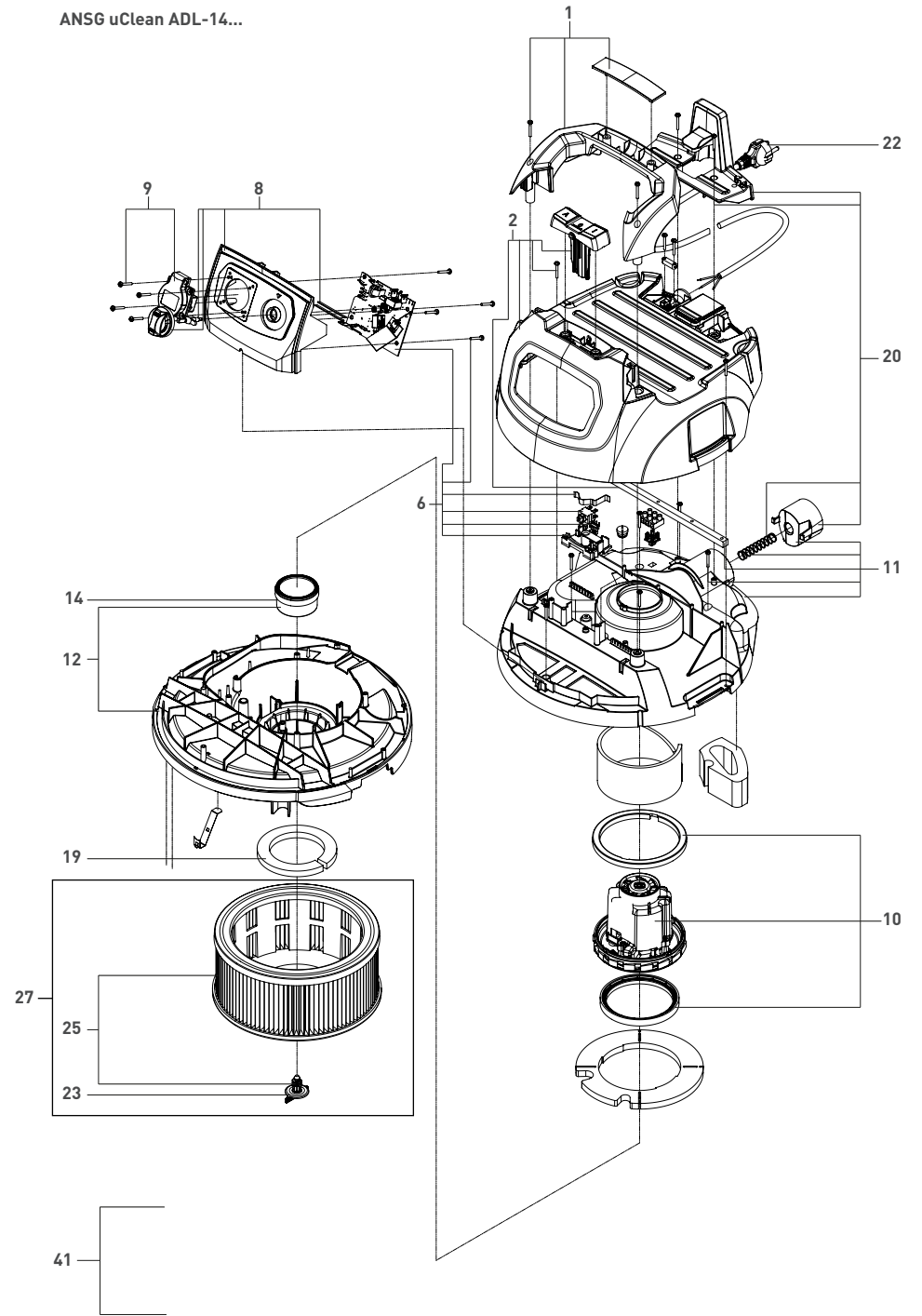
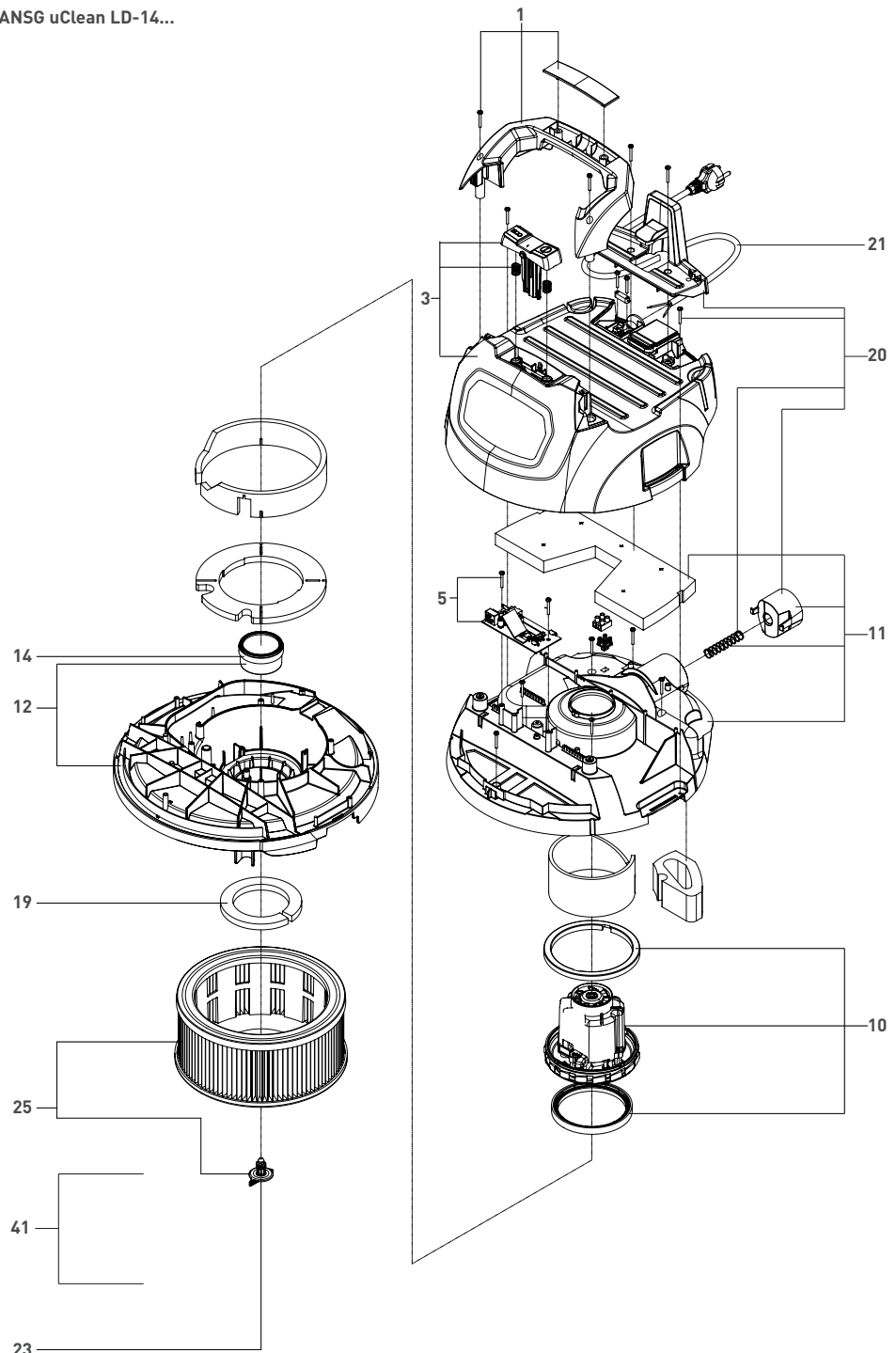

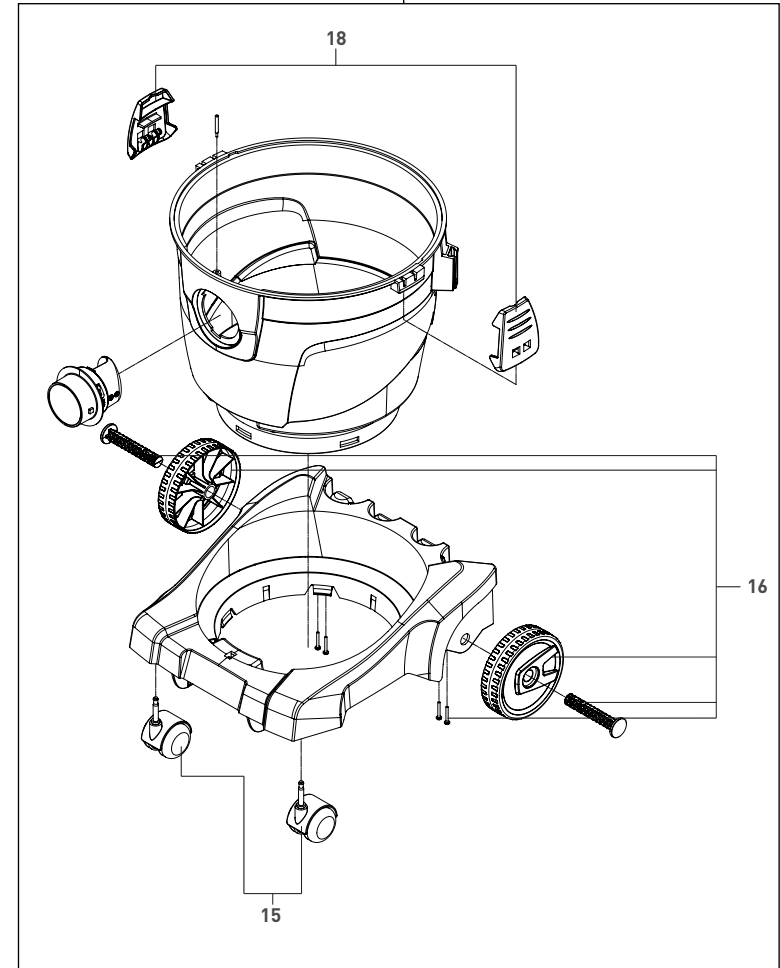
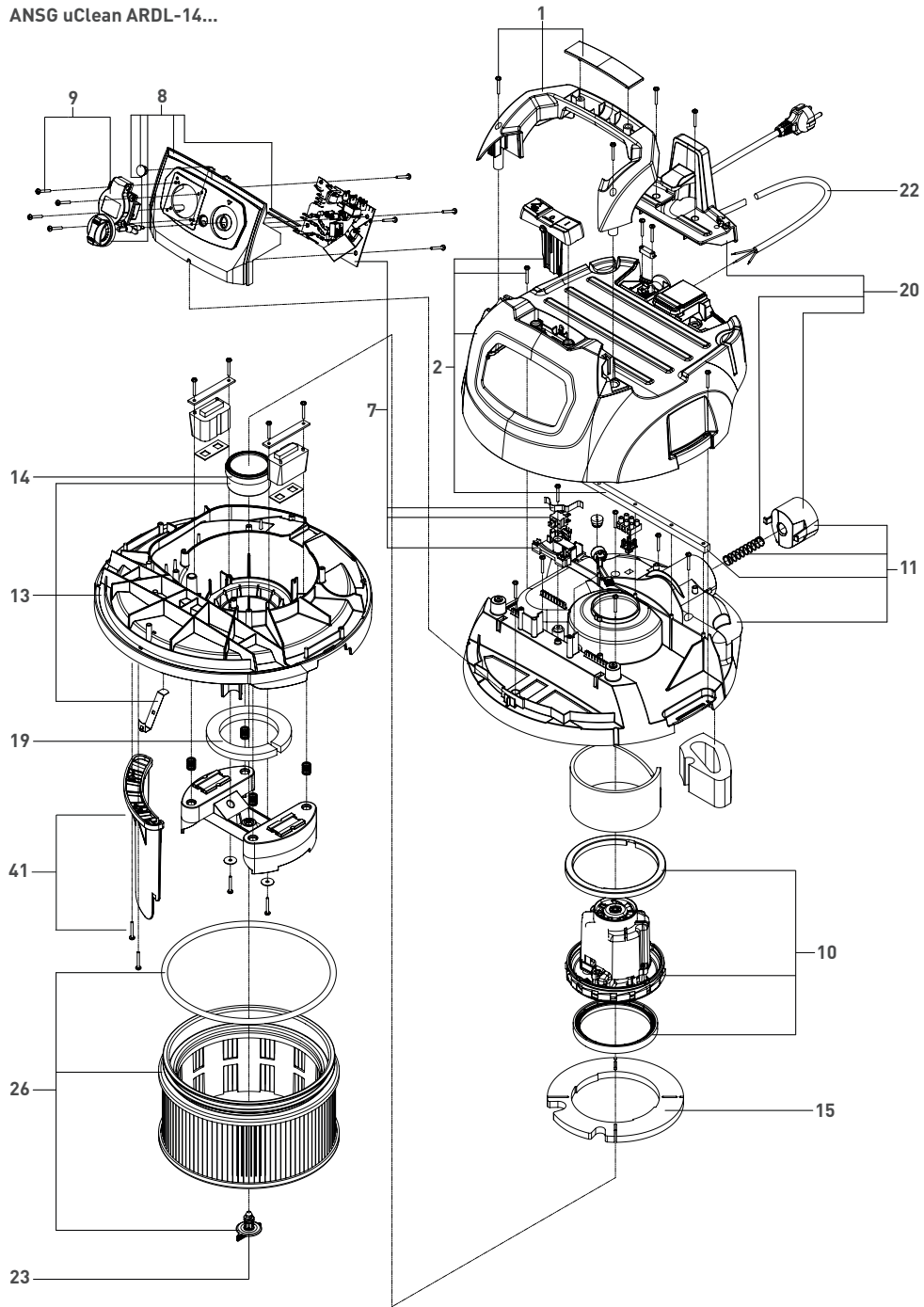

Current Model: ANSG1435A Stainless 35L

30 - 35L
37 - 22L

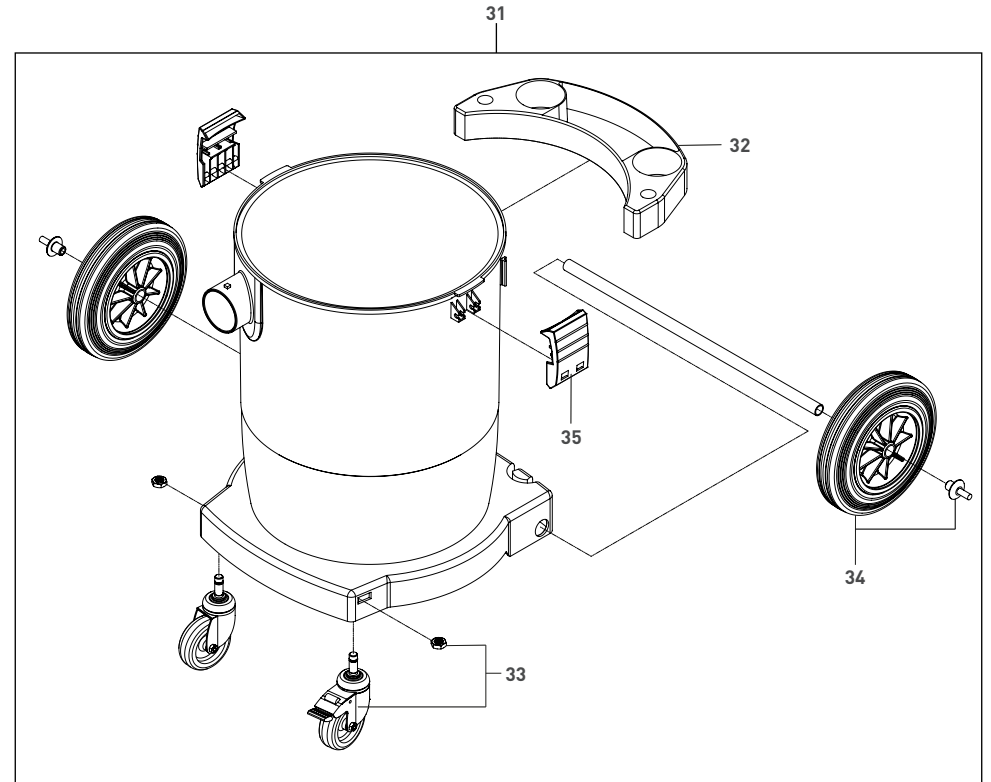
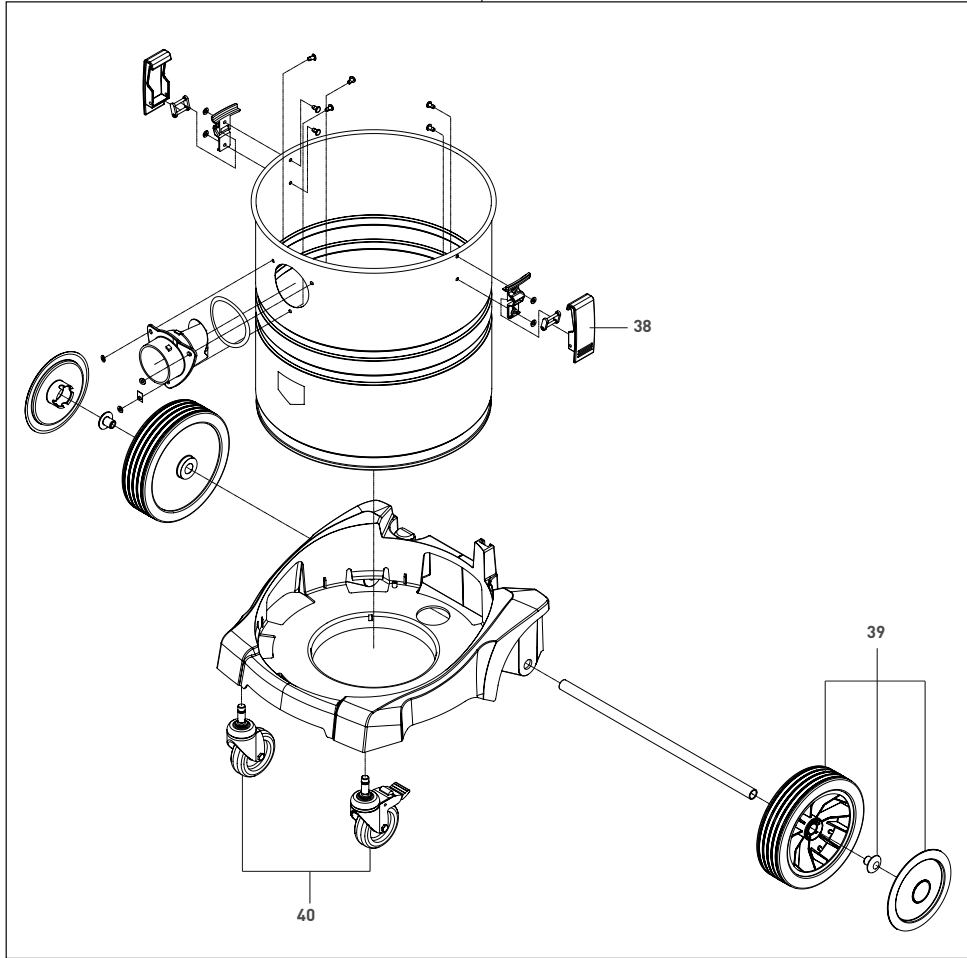

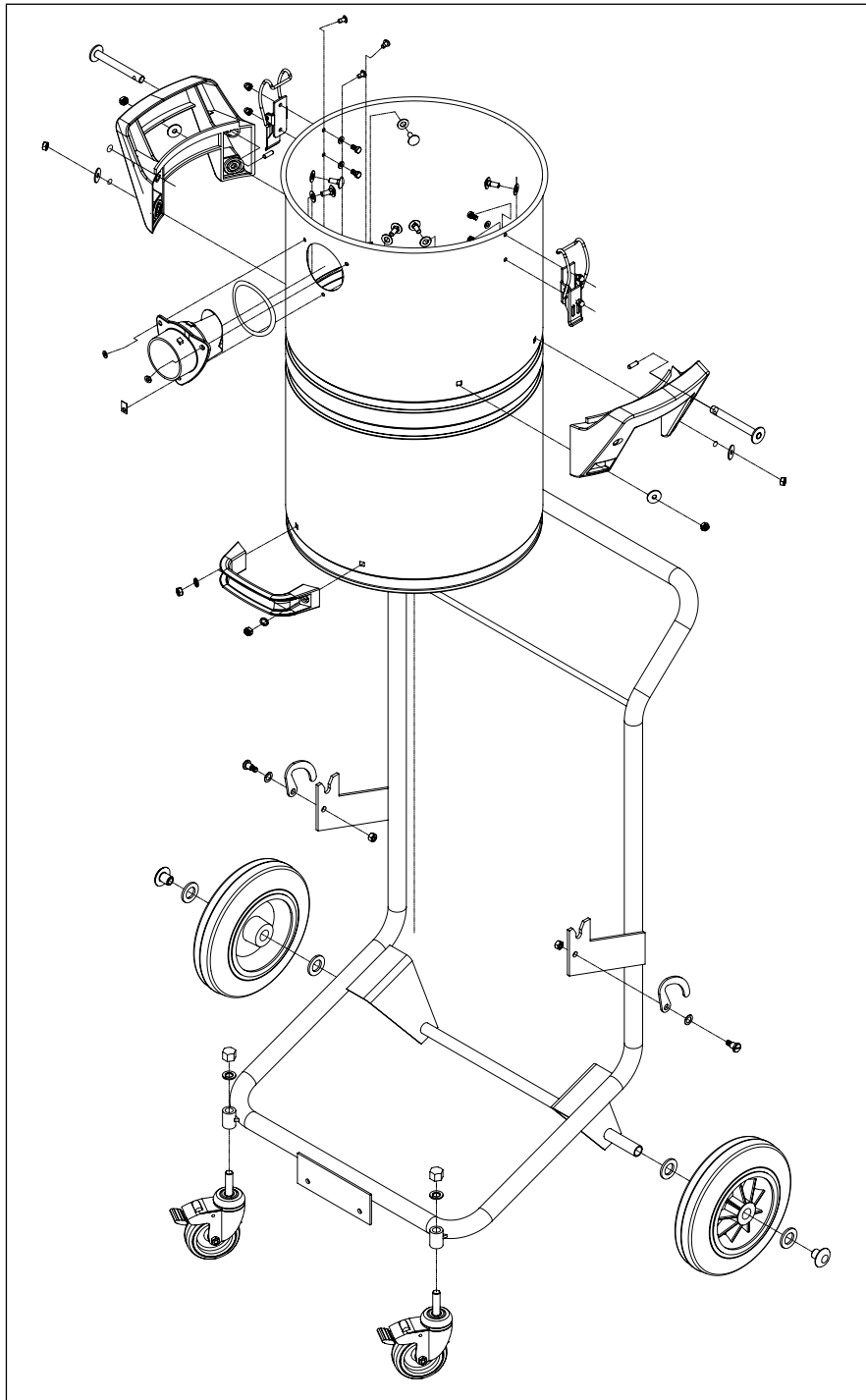

Ersatzteile/Spare Parts

Stand/Issue: 15-01

A - ANSG uClean ARDL 14 ..
 B - ANSG uClean ADL 14 ..
 C - ANSG uClean LD 14 ..
 D - ANSG uClean 14 ..

Pos.-Nr. Item No.	Bestell-Nr. Order No.	Typ Type
1	441023	A - D
2	441030	A - B
3	441047	C - D
4	441054	D
5	441061	C
6	441078	B
7	441085	A
8	441092	C - D
9	441108	C - D
10	441115	A - D
11	441122	A - D
12	441139	B - D
13	441146	A
14	441153	A - D
15	440859	A - D
16	440798	A - D
18	440774	A - D
19	441177	A - D
20	441184	A - D
21	592978	C - D
22	593326	A - B
23	441191	A - D
24	411729	D
25	415109	B - C - D
26	413464	A
27	413372	A - B
28	440675	A - D
29	440712	A - D
30	440743	A - D
31	440750	A - D
32	526669	A - D
33	440897	A - D
34	440828	A - D
35	440835	A - D
36	440767	A - D
37	440705	A - D
38	440781	A - D
39	440811	A - D
40	440880	A - D
41	441269	A-D

Thank you for choosing an Intex product!

To register your warranty, complete our online form @ intexinternational.com or scan QR below.



Warranty Statement:

Intex Group International Pty Ltd (*Intex*) guarantees that all products manufactured by and or for Intex shall be free from defects under normal use. Your registered warranty means that the product you have purchased is covered against such defects, in accordance with any specific warranty period and conditions stated in the manual enclosed with the product.

Warranty may invalidate due to:

- Expiry of the warranty period.
- Incorrect and unsuited product use (*i.e. not in accordance with Intex operation manual*).
- Unfulfilled specified product service or maintenance requirements.
- Careless and unsuited product handling (*i.e. damage caused by impacts, falls and climatic influences*).
- Wear and tear to normal wearing parts (*e.g. brushes, bearings, sleeves, consumable accessories etc*).
- Battery Pack faults or defects after 700 charging cycles (*even if identified inside the warranty period*).
- Product changes or modifications made from the new and original state without prior written approval from Intex.
- Service and or repairs performed by non-Authorised Intex Service Agents and or personnel.
- Non-original and genuine Intex spare parts, accessories and or consumable materials used.
- The product not being manufactured by and or for Intex.
- The product not being purchased from Intex or an Authorised Intex Reseller.
- Intex and or the Authorised Intex Reseller not having been paid in full for the product.

To find a local Authorised Service Agent, view the warranty claim process or read our terms and conditions visit intexinternational.com



intexinternational.com

Intex

Power Tools



UseitTM **starmix**
Super Tools
Dust Extractors

Starmix® & Useit® are registered Trademarks of Intex International. The information contained in this brochure was correct at the time of printing. E&OE